

OPERATION INSTRUCTIONS

KRW 20



MODULAR PLATFORM
BUILD YOUR CONFIDENCE
WEAPONS

KRW

**MODULAR PLATFORM
WEAPONS**
BUILD YOUR COMFORT



Hello,

THANK YOU for purchasing of a self-loading pistol from the **KRW 20** family of weapons.

Before handling the weapon, read these operating instructions including the safety instructions. Incorrect manipulation and misuse of weapon as well as arbitrary modifications, corrosion and use of damaged or unprescribed cartridges can cause accidental shot, subsequent damage to property, injury or death.

Before the weapon was put on sale, it was properly tested by shooting, including the high pressure proof shot, it was checked and packaged. Anyway the manufacturer can not control the weapon handling after weapon leaving his warehouse. Therefore, when receiving your weapon check it carefully to be sure that it is undamaged and unload.

These operating instructions should always be attached to the weapon even if you sell or borrow the weapon.

SAFETY INSTRUCTIONS

Your capability of safe weapon handling should be proven by your gun licence. In order of your own safety and of your surroundings always pay attention and follow safety instructions for weapon handling.

- Always handle a weapon as if it is loaded
- Do not trust anyone saying that the weapon is not loaded
- Never aim at anything you do not intend to shoot
- Use appropriate ear and eye protectors (protective shooting goggles) during shooting
- Never use the weapon for any purpose other than shooting
- Do not leave a loaded weapon unattended
- Before putting weapon down or handing weapon over to another person, make sure that it is not loaded
- Store the weapon unloaded and with decocked firing mechanism
- Use only undamaged, dry, clean and original ammunition in good condition, high quality ammunition – caliber 9mm Luger / 9x21 according to C.I.P. standard
- Before loading, make sure that the bore of barrel, the chamber and the bolt are clean, without obstacles and that the weapon is undamaged
- After shooting clean the weapon as soon as possible
- When the weapon is loaded and cocked, keep the safety catch on until you are ready to fire
- Do not block the ejection port and make sure that nobody is a hindrance in the direction of the ejected cartridge
- During shooting – hold the weapon with the prescribed grip on the handguard, do not put your hand in front of the barrel; do not hold the weapon by the magazine or rest the weapon against the magazine
- Do not pull the trigger or do not put your fingers into the trigger guard unless you aim at the target and are ready to fire
- Never shoot at hard surface such as stone or water level
- Do not shoot near an animal if it is not trained for this noise
- Before you press the trigger, once again check your target and the space behind it
- Before cleaning, storing, carrying any or other weapon handling not directly associated with the shooting, make sure the weapon is not loaded
- If a shot fails, hold the weapon aimed at the target or at the safe place for at least 30 seconds to 1 minute. If there is no firing, remove the cartridge from the chamber and examine it. If there is a indent mark from the striker, then the cartridge has to be disposed of by a specialist and weapon has to be checked by specialist before the next shooting
- Never modify the weapon components. This may cause serious damage to its function and safety
- Corrosion, the use of defective cartridges, the fall on hard surface and other rough handling, can cause a damage that is not visible at a first glance. If this happens the weapon has to be checked by an expert gunsmith.
- Keep the weapon and ammunition separately in a locked area, away from unauthorized persons and children

Type: **SEMI-AUTOMATIC PISTOL**
Name: **KRW 20**
Producer: **KR-WEAPONS**
Caliber: **9mm Luger / 9x21**

KRW 20



120mm barrel (version 1)

Barrel length

120mm

Weapon overall length

586mm / 357 – folded butt

Weapon height

179mm with mechanical sights

Weapon width

51.6mm (body 34mm)

Weapon weight

2,25kg – steel body



202mm barrel (version 2)

Barrel length

202mm

Weapon overall length

668mm / 439mm – folded butt

Weapon height

179mm with mechanical sights

Weapon width

51,6mm (body 34mm)

Weapon weight

2,47kg – steel body



202mm barrel (version 3)

Barrel length

202mm

Weapon overall length

642-692mm / 435 – folded butt

Weapon height

194mm with mechanical sights

Weapon width

51,6mm (body 34mm)

Weapon weight

2,70kg – steel body

Basic description

The weapon is intended for sport and target shooting as well as a weapon for personal and property protection. It is fitted by a four piccatinny rail according to MIL STD 1913 – by 90° around the barrel axis.

The main rail for sights is a part of the weapon's top cover, carrying basic mechanical sights or a collimator sight. The side rails are intended for attachment of tactical accessories (e.g. suitable for attachment of a tactical light). The lower rail is intended for attachment of a tactical pistol grip to improve the holding of the weapon. In the grip of the weapon is created shaft for a reserve magazine. By default, the weapon uses Glock Gen4 magazines – 10, 15, 17 and 33 shots.

The weapon is supplied in several production versions – with barrel length 120mm, 202mm or 254mm.



254mm barrel (version 4)

Barrel length

254mm

Weapon overall length

715mm / 486mm – folded butt

Weapon height

179mm with mechanical sights

Weapon width

51,6mm (body 34mm)

Weapon weight

2,51kg – steel body



254mm barrel (version 5)

Barrel length

254mm

Weapon overall length

689-739mm / 482mm – folded butt

Weapon height

194mm with mechanical sights

Weapon width

51,6mm (body 34mm)

Weapon weight

2,73kg – steel body



202mm barrel (version 6)

Barrel length

202mm

Weapon overall length

668mm / 439mm – folded butt

Weapon height

179mm with mechanical sights

Weapon width

51,6mm (body 34mm)

Weapon weight

2,34kg – steel body

WEAPON FUNCTION

The weapon fires from the closed bolt (front position) working as a blowback system, i.e. the chamber is closed by the mass of the bolt and by the force of recoil spring of the bolt. For secure closing of the chamber combination of these two forces is necessary.

However, this force is smaller than the pressure force that effects on the base of cartridge. The pressure force is caused by combustion (by explosion) of gunpowder contained in the cartridge. Due to this disbalance the functioning of the weapon can be kept. This force generated by the combustion of gunpowder in the cartridge is bigger than the force closing the bolt and therefore the bolt is moved to the rear position by this pressure/force and then it is returned by the force of the recoil spring. This ensures functioning of weapon.

For a description of the weapon's function assume that the weapon is without magazine, it is unloaded, the firing mechanism is in the released position and the bolt is in the front position – safety is off.

Before shooting, we grab the weapon (right-hander in right hand, left-hander in left hand) for the grip of the weapon (keep in mind and follow all safety rules for weapon handling) and we insert the magazine into the weapon. The magazine is inserted into the magazine shaft located in front of grip of the weapon and in front of the trigger guard.

We insert magazine containing cartridges (9x19 according to C.I.P. standard) and we push magazine with adequate force so that the magazine catch (style of M16) locks in to the right place. The magazine catch is controlled by forefinger of right-handed shooter or by thumb of left-handed shooter. Once the magazine is inserted and locked by the catch, we pull down the magazine – we will find out if the magazine is in the right position in the weapon and if the catch holds it positively. We never push the magazine with force or stroke. This is especially true when the bolt is held in the back position after the last shot.

The pistol magazine Glock is limited in the weapon by a stop of the grip. Because there is a possibility to insert 10shots magazine into the weapon KRW 20 (for which the length of the shaft is adjusted), the longer magazines have no stop that the magazine can reach by force. In the case of such a force or shock insertion of the magazine, the feeding lips of the magazine may be damaged because of getting stuck in the shaft or there may occur (if the bolt is in the rear position) move of magazine to the area of the bolt, which prevents the releasing of the bolt and the proper loading of the weapon.

If the magazine is in its proper position, that is, if the magazine catch snaps into the window of the magazine and magazine is securely held in the weapon, then it is possible to load the weapon.

We grab the cocking lever of the bolt which can be inserted into the weapon from both sides (from right side and from left side too) and we pull the bolt towards the back (to the shooter's shoulder) until it reaches the rear part of the weapon. Striker is moved against its return spring/mainspring during this movement. It is situated in the bolt of the weapon. We release the bolt that reached the bumper in the back position. We never help with the move of the bolt forward.

When the bolt is moving backwards, securing of the trigger against denting/pressing is created by the part of blocking of trigger after 1-2 mm of its trajectory. This is true if the bolt is not safely in its forward position and if it safely does not lock the chamber.

Therefore, if the chamber is not safely locked, it is not possible to pull the trigger and thereby release the striker to prevent a dangerous shot.

With this function, it is possible to immediately find out, whether there is a defect on the weapon that prevents the safe closing of the bolt (not ejected cartridge, misdirected cartridge, bad calibration not conforming to the C.I.P. standard on which the chamber is made or the bolt is at its slide stop catch after the last shot.

The bolt is brought back into the rear position by cocking lever and is released. We never help with the move of the bolt forward.

Recoil spring ensures this process separately. With this movement in the first stage, the bolt (with striker) is moved forward to the point where striker is caught on its sear (the projection that is part of the trigger mechanism of the weapon and it is actuated by the trigger) – this all by the recoil spring of the bolt and by mainspring of the striker. The bolt continues forward and its feeding rib pushes the cartridge from magazine and further on to the chamber. During the last 2 mm before closing the chamber, the bolt cause by its projections against the projections of the blocking of trigger and the bolt moves the blocking of trigger about 2 mm forward to release the trigger and safely locks the chamber.

The base of the cartridge on the bolt is so called open – pistol character and basically in this movement the edge of the cartridge is moved under the extractor which is part of the bolt and is used to pull the empty cartridge out after shot or it is used to pull the cartridge out if the weapon is loaded and if shooting is finished.

Now the cartridge is in the chamber and the striker is cocked – it is located on its catching lug and its spring is compressed/tightened.

!! Use appropriate ear and eye protectors during shooting !!

If we want to shoot, we grab the weapon with the free hand so that the fingers are leaning against the lower piccat-

iny rail and the palm is rested against the magazine shaft. **We never grasp the gun so that the fingers holding the handguard reach muzzle** and we place the weapon comfortably into the shoulder. We aim at the target by mechanical sights or by collimator and then we put the forefinger of the shooting hand on the trigger. **We never hold the weapon by the magazine and we do not rest the magazine of the weapon against the pad.**

We pull the trigger with a smooth motion towards the back (to the shooter's shoulder) – we will feel two stages of resistances of trigger in this movement. The first trigger resistance (lesser resistance generated by the trigger spring) unlocks the blocking of the striker. This blocking of the striker is directly connected to the trigger – *this is solved so that the spring controlling the blocking is also spring controlling the trigger, because the spring controls the blocking of the striker and the trigger and its return to its original position is controlled by second part of the blocking.*

As soon as we feel the second – the larger trigger resistance, the trigger reaches the control part of the sear. The sear is compressed by another movement (the disconnecter pushes upward one part of the sear by the trigger and the second side, where the sear is stopped, is compressed downward to the point where the striker is released – that all by the rotation of the sear around the axis of its pin.

When the striker is released, it stops acting by its pressing force against the sear and the sear does movement by its spring. During this movement, the sear leaps out from disconnecter backward to the shooter's shoulder about 2 mm and rotates around its pin so that it again creates the position for stopping.

The striker continues forward to hit the primer. There is an ignition/explosion of gunpowder – the shot. The pressure of gases generated by combustion of the gunpowder pushes the bullet from the barrel and acts by force that overcomes the force of dynamic locking and the bolt with the striker is thrown (controlled by its guidance) towards the back against its own return spring to the stop (extended metal part of the guidance of the firing pin spring and behind it there is a absorbing rubber bumper that is leant by its back part against the weapon body.)

During this backward movement, the cartridge is pulled out of the chamber mainly to the point where its part collides into the lug of the ejector, which is part of the bolt body. The bolt continues backwards. The cartridge, which is held by the lug of the ejector, does a rotary movement around the lug of the ejector toward the right side of the weapon, where there is the port in the weapon body. The cartridge is ejected from the weapon through this port. The bolt completes its backward movement, where it strikes the bumper and the striker stops by the lug of the sear because of movement forward (as described above) and the weapon is loaded, if there is another cartridge in the magazine).

In case that there is no cartridge in the magazine before the shot, the magazine creates standby position for the bolt by its magazine follower by the lever of the sear and the bolt stops in front of the magazine when it moves to its forward position.

We remove the magazine – we press the button of the magazine catch by forefinger of the right hand (applies to right-handed shooter) and the magazine fall out of the weapon. Then we insert a new magazine and we move the bolt slightly backwards (or as far as it will go) by the cocking lever and then we release it. The weapon will be reloaded and the weapon is ready for the shot.

The button of the safety, that directly blocks the trigger, is behind the trigger. If the button is in its center position, the weapon is with the safety catch on. In this situation, there is possibility to manipulate with weapon – it is possible to move with the bolt and safely unload and load the weapon.

The releasing of the safety catch is done by moving the button to one side or the other to the stop – it is advantageous that the right-handed shooter releases the safety catch by forefinger by moving the safety button from the right side to the left and then puts the safety catch on by the thumb of the right hand after the finishing of the shooting by moving the safety button from the left side to the right – but not to the stop, only to the center position of the button!

In this central position, the button fits with the contour of the grip of the weapon and this is certainly in case of putting the weapon down on a indented pad and self-releasing of the safety catch that do not occur due to this structural design.

The mechanical sights are designed to be attached to the weapon by an Allen screw with a square nut. To remove the sights, you need to completely pull the screw out of the sights carrier (be careful – not to lose the nut) and take sights down from the sights rail. The screw provides a clamping connection of the sights with the rail. The height adjustment of the front-sight is carried out by pressing the arresting pin of the front-sight and by rotation of the front-sight – the arresting pin puts the front-sight into its right position. The rear sight is adjustable laterally and it is enough to rotate the screw of the rear sight, which is locked by the arresting pin of the rear sight automatically.

Another feature of the manipulation is a folding butt with a plastic buttplate. This butt is tilted in such a way that the weapon is turned by its grip and magazine shaft against the shooter's body while being controlled by the left hand. The right hand holds the butt as close as possible to the weapon, the thumb of the right hand is leant against the lower part of the joint (the joint is firmly connected to the weapon). The fingers of the right hand grasp the butt and then it is necessary to press the butt by fingers against the acting force of the thumb of the right hand.

The whole arm of the butt carrying the buttplate is pressed against the spring of the arm joint – it jumps out of his lugs and then it can be tilted to the right side of the weapon. After fully folding of the butt, the arm of the butt clicks again into the lugs. Releasing of the arm of the butt and returning to the open shooting position is performed in a similar way.

BASIC CONTROLS OF THE WEAPON

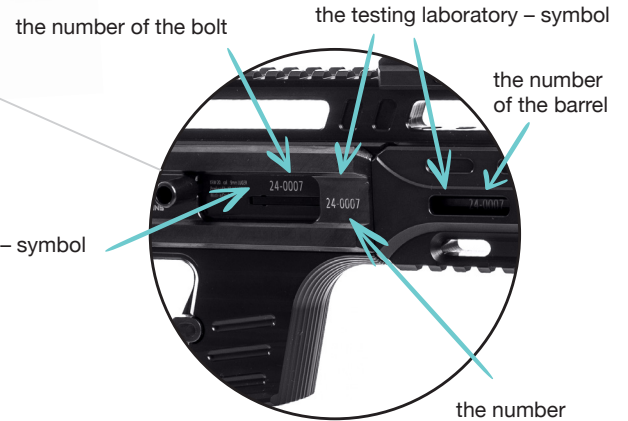
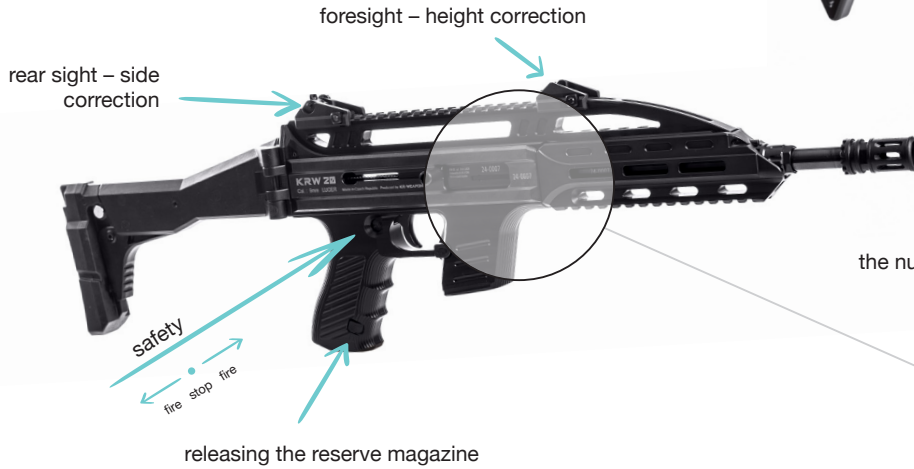

manufacture year
serial number

the number of the weapon is in **XX - XXXX** format mentioned on each major part of the weapon (weapon body, barrel, bolt)

DISASSEMBLY – REASSEMBLY

Disassembly and subsequent reassembly is performed for the purpose of cleaning or checking the weapon and its components.

DISASSEMBLY

First, we make sure (in a safe way respecting the safeting the safety rules) if the weapon is unloaded, the firing mechanism is released and the magazine is removed.

We place the weapon by muzzle (by flash suppressor) on a strong pad – the butt is in the open/firing position. We hold the butt at the point of the buttplate with the right hand and with the left hand we hold the weapon's body and we push the button located in the area of the rear part of the weapon between the cover and the joint of the butt – that all by forefinger of the left hand. (fig. 1)

It is the end of a part called a recoil spring guide rod that protrudes back to the the assembly of the butt as a security stud and holds the butt plate in the correct position.

For the version of the weapon using the BREN 805 butt, the stopper of the stock is pressed in the same way, which directly controls/compresses the recoil spring guide rod by its projection as described above.



fig. 1

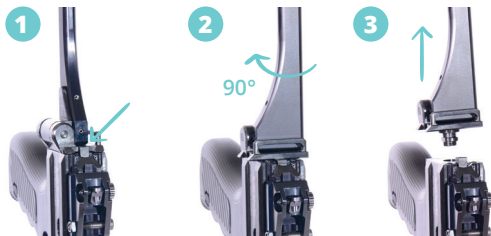

fig. 2

We press this button by the thumb of the left hand against the return spring of the bolt. As soon as it is released from the hollow in the carrier of the butt, we turn the buttplate by 90° by the right hand (in this case of the grab it is by 90° to the right). After this operation, when we turned the butt by 90°, we pull out the butt from the weapon. (fig. 2, 3)

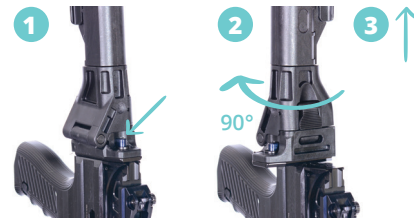

fig. 3



fig. 4

The type of the carrier of the butt with the nose for the belt protruding to the left side of the weapon – it is necessary to rotate with the butt/stock to the opposite (left) side – oppositely as shown in the figure.

We place the weapon on a strong rest by the magazine shaft and by the grip.

With the left hand, we hold the handguard of the weapon and with the right hand, we pull out the weapon top cover from the rails of guidance in the weapon body. (fig. 4)

We carefully remove the recoil spring guide from its stop area and we also remove recoil



fig. 5

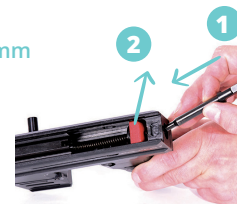

fig. 6



fig. 7

spring from the weapon and from the bolt. (fig. 5) We push the rear part of the guide of the striker spring by a thin handy tool (pencil, ballpoint pen, extension rod of the bore brush or the guidance of the return spring of the bolt), we move it forward and we take the mainspring including its guidance and its rubber stop out from the weapon by the fingers of the left hand in a suitable way. (fig. 6)



fig. 8

We remove the bolt to the rear position by using the cocking lever and then the cocking lever will be released. We remove the cocking lever to the side of the weapon – away from the weapon. (fig. 7) Then we basically grasp the front part of the bolt and we take it out from the weapon (the bolt must always be in the front position). There is the striker in the bolt, which can be freely removed from the bolt. (fig. 8)

Again, we place the partially disassembled weapon (the weapon body with the barrel and the grip carrying the trigger mechanism) on a strong rest by its muzzle/flash suppressor. With the left hand, we grasp the rear part of the weapon body and we push it against the pad. With the right hand and with the force pressed in the opposite direction from the pad, we grab the grip and we move the whole set of the grip with the trigger mechanism about 10 mm to the position, where the grooves and the protrusions on the weapon body are lined up. (The grooves and the protrusions are not visible – it is learnt movement.) Then the grip can be removed from the weapon. (fig. 9)



fig. 9

If we are still interested in removing the barrel from the handguard, we push the arresting pin of the flash suppressor to the stop and we screw out the flash suppressor.



fig. 10

For the version of the weapon with longer barrel, first we screw out the flash suppressor and then we push the arresting pin locking the barrel nut, which we also screw out and remove from the barrel. Then the handguard can be pulled off from the barrel with using of adequate force. (fig. 10)

This basically completes the disassembly of the weapon for perfect cleaning.

REASSEMBLY

The reassembly is performed in the reverse way then the disassembly was performed – keeping the procedure which is described below.

First we put the grip panel into the weapon in the opposite way as we removed it from the weapon and we release the safety catch.

Subsequently, we insert the striker into the bolt and align it so that the lower edge of the striker is placed horizontally with the underside of the bolt – the striker is centered. We insert the bolt into the weapon in its rear position and we check by slowly movement about 10-15 mm forwards, if the striker runs into its guidance grooves (the check is from the top view). (fig. 11)

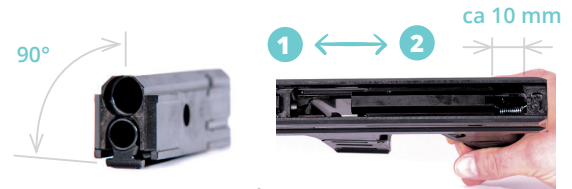

fig. 11

If the striker is in its grooves, we will again move the bolt backwards and insert the cocking lever, we align it with the guidance groove in the bolt and then slowly move the bolt forward. (fig. 12)



fig. 12

fig. 13

As soon as the striker stops on sear (fig. 13), we immediately push the striker with the forefinger (we hold the weapon with the right hand during pushing the striker). The striker moves about 2 mm forward and we keep the pressure until than we move the bolt forward to the end with the remaining fingers of the left hand. (fig. 14)



fig. 14

This is necessary for the releasing the trigger. The bolt is now in the front position under the constant pressure of the remaining fingers of the left hand and the forefinger is still pressing the striker. We pull the trigger – the striker is moved forward.

We insert the return spring of the striker in the set with its guide including the absorbing rubber pads. We arrest the absorbing rubber pad so that in one part of the rod of the return spring extends with its large diameter over the absorbing pad (the absorbing pad has chamfered edges on this side for better insertion into the weapon body).

With this part, the absorbing pad is turned downwards into the weapon body. We insert the return mechanism of the striker into the hole in the weapon body by double movement of pre-pushing of the spring towards the striker and repeated returning the return mechanism of the striker. (fig. 15)

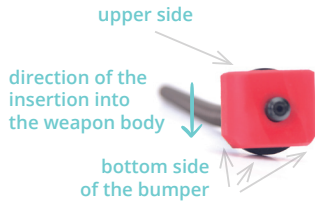

fig. 15



We grab the cocking lever of the bolt and pull it back, move forward (the striker stays on the slide stop catch), pull the trigger and we perform the blind shoot – check the correct insertion of the return mechanism of the striker. (fig. 16)

In a similar way, we insert the recoil spring of the bolt and its guide so that we push it towards the bolt and hook the projections of the return spring into the weapon body. (fig. 17)

Then we insert the cover into the weapon by inserting it into its grooves in the weapon body. (fig. 18)



fig. 17

It is necessary that grooves in the weapon body (or the handguard) and the guide of the weapon cover are clean, free of dust, sand etc., and slightly lubricated, with a light oil filter on the grooves of weapon body (handguard) and also on the weapon cover. We put the weapon cover to the stop.

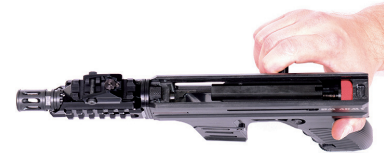

fig. 16

We place the weapon by muzzle on a strong pad and we align the weapon cover and the grip panel with the rear side of the weapon body by pushing the weapon top cover and the grip panel against the pad. We push the guide of the recoil spring of the bolt, we insert the butt/stock into its guide in the bolt body (turned by 90°)



fig. 18

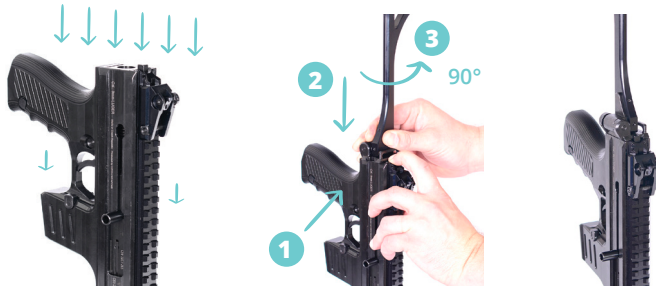

fig. 19

and we rotate it by 90° so that the stock is locked in its position. The projection of the return spring of the bolt clicks into the place, the butt/stock is locked. (fig. 19)

The type of the carrier of the butt with the noose for the belt protruding to the left side of the weapon – it is necessary to put the butt/stock turned by 180° – oppositely as shown in the figure.

We grab the weapon as it is when we loading, we pull the bolt backwards several times, we release the cocked striker by the pulling the trigger – check of the correctness of the reassembly of the weapon. All must work without getting stuck, under the pressure of the return springs.

CLEANING AND LUBRICATION

We always clean the barrel immediately after shooting with a suitable brush of the appropriate caliber, with the help of commonly available cleaning oils, such as WD40, Konkor 101, etc. Then we wipe it dry.

If we keep the light oil layer in the barrel because of storage conditions, we always wipe the barrel dry before shooting.

We clean the other dirty surfaces of the bolt and the weapon body with cleaning oils as soon as possible after

shooting. Then it is possible to wipe the parts dry or there may remain slight oil layer (it is not necessary to soak the parts of the bolt, weapon body or trigger mechanism in oil bath, because their correct function is ensured with a dry working surroundings or with a slight oil layer).

The grip panel – it is not necessary to soak the internal parts of the trigger mechanism in oil bath. It is enough to wipe it dry. If the components get stuck because of dry, it is advisable to apply a slight oil layer.

In case of hard fouling (remaining particles of gunpowder), it is possible to blow the area around the components out with compressed air, always in such a way no dirt is pushed into the trigger disconnecter. The condition is to blow the dirt out, not to push it into the functional spaces of the trigger mechanism. After cleaning with compressed air, it is necessary to move with all possible parts so that any impurities fall out, then re-clean them with compressed air, apply the cleaning oil and remove excess oil by blowing out with compressed air again.

Such a cleaned trigger mechanism is considered to be perfectly oiled. It is necessary to treat the compressed air carefully so that dirt does not come into contact with the functional parts of the components.

After assembling the weapon and also for case of the long-term storing, it is advisable to keep a light oil layer on the components (also from outside), especially on the steel weapon body (its surfacing is bluing). It is advisable to treat the bluing with a slight oil layer for long-term colour sustainability and as protection against later corrosion during storage in not entirely ideal conditions. The cleaning oils as WD40, Konkor 101, etc. are sufficient.

LIST OF PARTS – BREAKDOWN OF THE KRW 20 SET

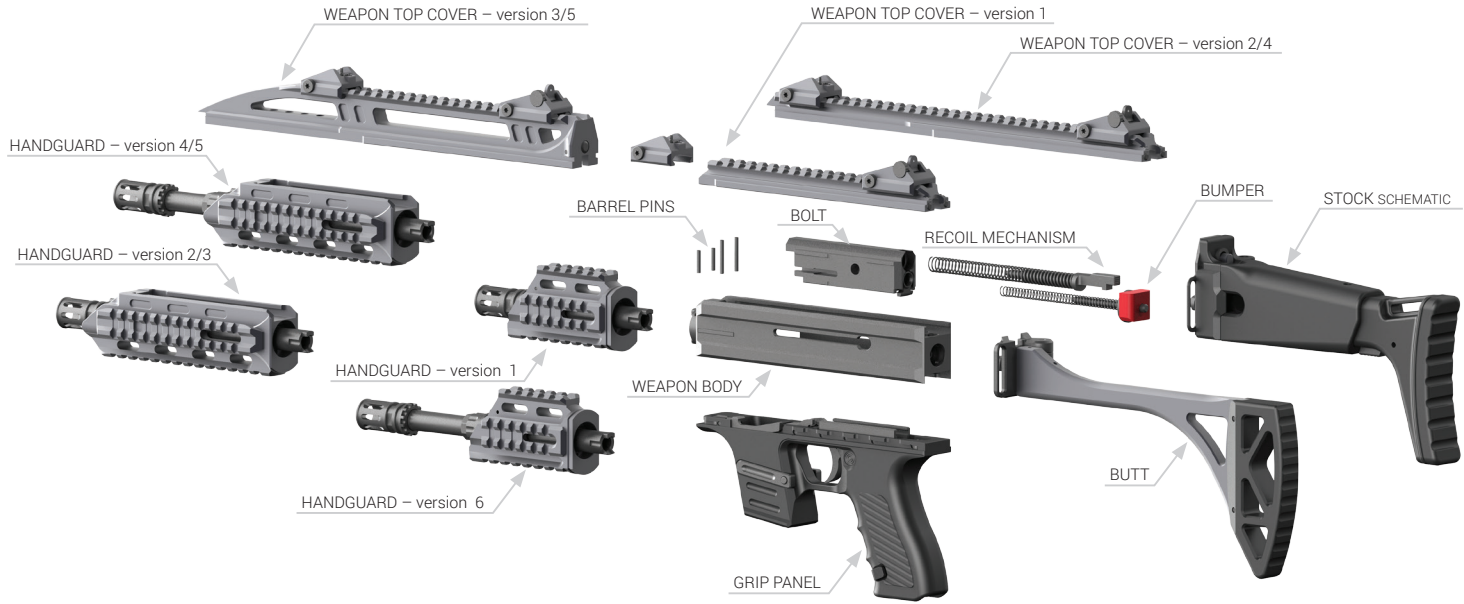

SET OF THE WEAPON BODY – BREAKDOWN OF THE COMPONENTS

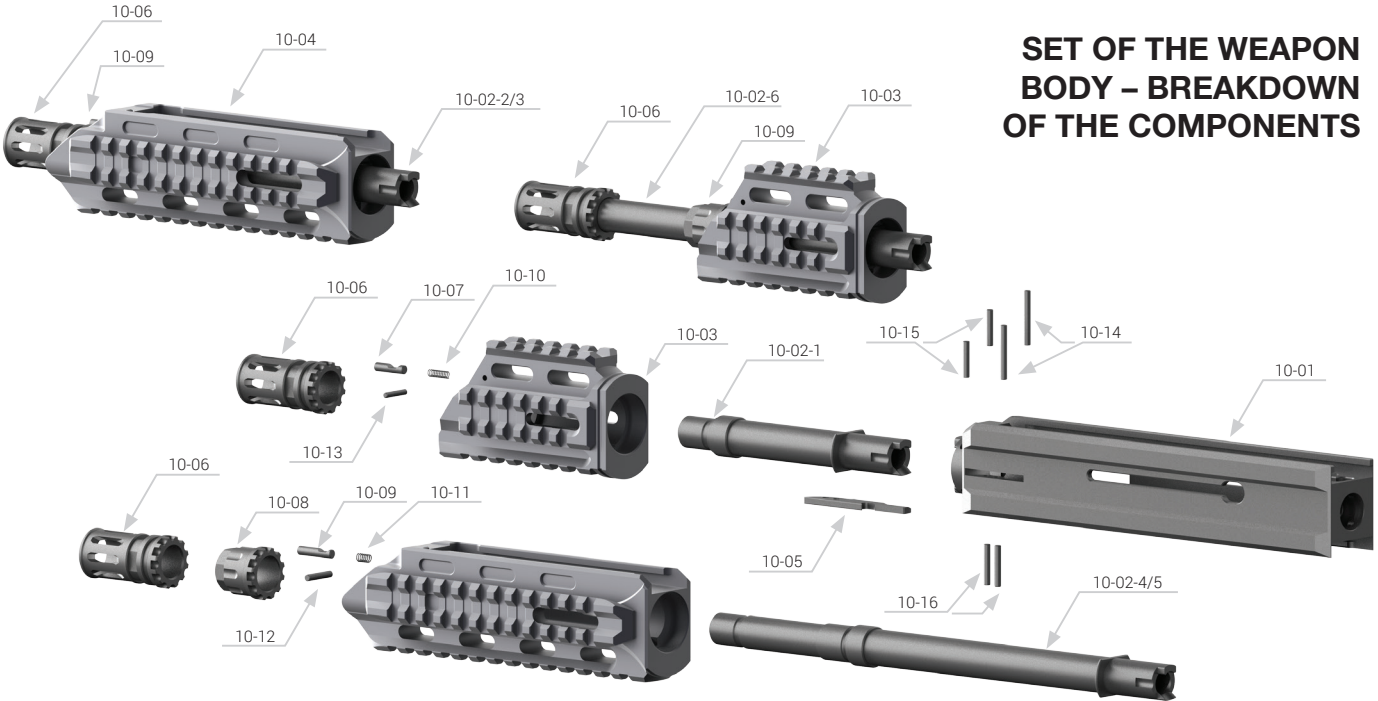

- 10-01 Weapon body
- 10-02 Barrel 120mm
- 10-02-2/3 Barrel 200mm
- 10-02-4/5 Barrel 254mm
- 10-02-6 Barrel 200mm

- 10-03 Handguard 1
- 10-04 Handguard 2
- 10-05 Ejector
- 10-06 Flash suppressor
- 10-07 Pivot of the flash suppressor 1

- 10-08 Ring of the barrel
- 10-09 Pivot of the flash suppressor 2
- 10-10 Spring of the flash suppressor 1
- 10-11 Spring of the flash suppressor 2
- 10-12 Pin of the flash suppressor 2

- 10-13 Pin of the flash suppressor 1
- 10-14 Pin of the barrel 1
- 10-15 Pin of the barrel 2
- 10-16 Pin of the ejector

SET OF THE BOLT AND THE RETURN MECHANISM OF THE WEAPON – BREAKDOWN OF THE COMPONENTS

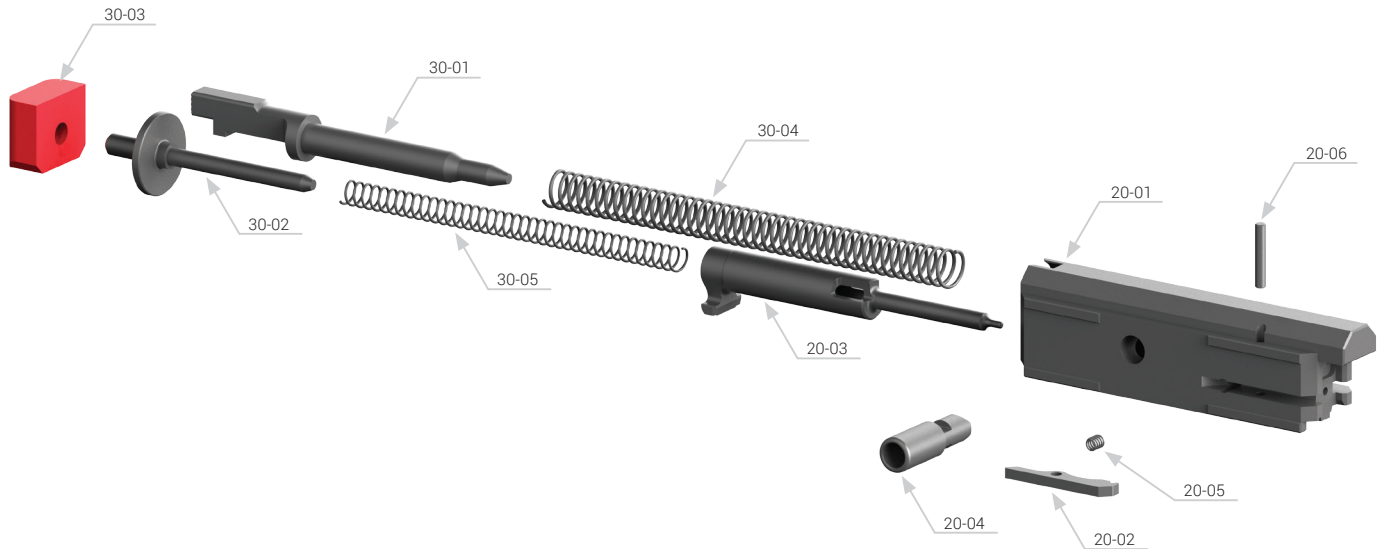

20-01 Bolt of the weapon
20-02 Extractor
20-03 Striker
20-04 Cocking lever

20-05 Spring of the extractor
20-06 Pin of the extractor
30-01 Carrier of the return spring
30-02 Rod of the striker spring

30-03 Bumper
30-04 Recoil spring
30-05 Striker spring

SET OF THE COVER AND THE BUTT OF THE WEAPON – BREAKDOWN OF THE COMPONENTS

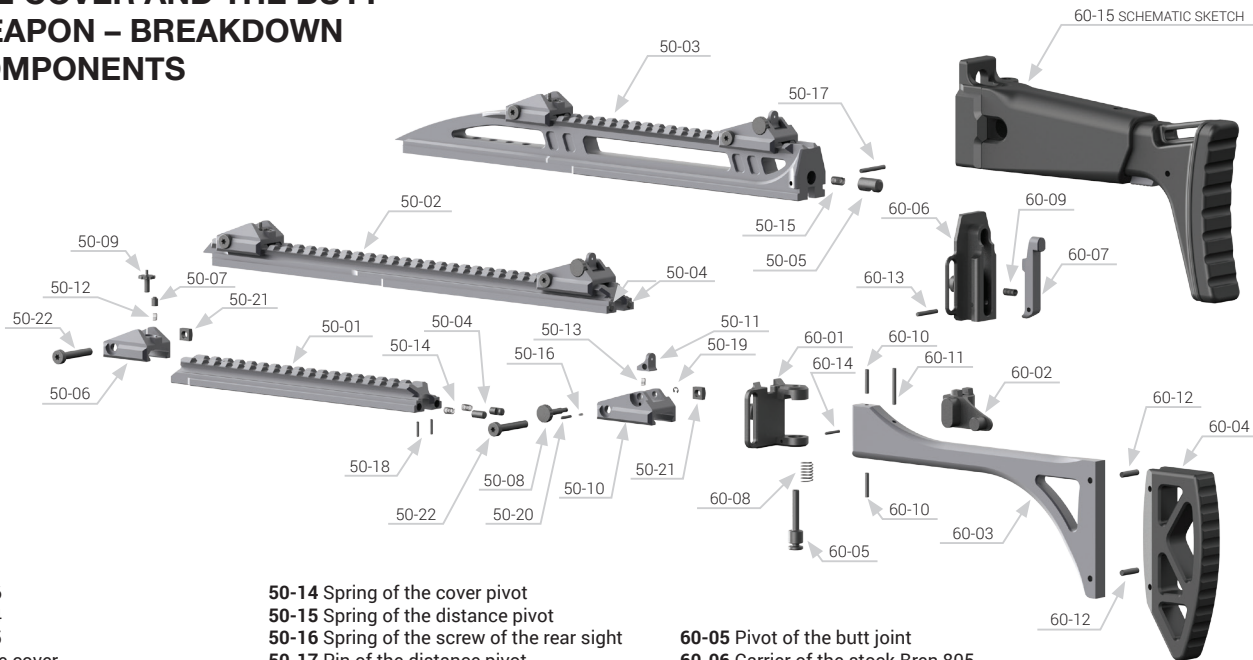

- 50-01 Cover v1/6
- 50-02 Cover v2/4
- 50-03 Cover v3/5
- 50-04 Pivot of the cover
- 50-05 Distance pivot
- 50-06 Carrier of the foresight
- 50-07 Arresting pin of the foresight
- 50-08 Screw of the rear sight
- 50-09 Foresight
- 50-10 Carrier of the rear sight
- 50-11 Rear sight
- 50-15 Spring of the foresight
- 50-13 Springs of the rear sight

- 50-14 Spring of the cover pivot
- 50-15 Spring of the distance pivot
- 50-16 Spring of the screw of the rear sight
- 50-17 Pin of the distance pivot
- 50-18 Pin of the cover pivot
- 50-19 Safety ring
- 50-20 Pivot of the screw of the rear sight
- 50-21 Ring of the screw of the sights
- 50-22 Screw of the sights
- 60-01 Carrier of the butt
- 60-02 Butt joint
- 60-03 Butt
- 60-04 Buttplate

- 60-05 Pivot of the butt joint
- 60-06 Carrier of the stock Bren 805
- 60-07 Stop of the stock
- 60-08 Spring of the pivot of the butt joint
- 60-09 Spring of the stop of the stock
- 60-10 Pin 3x16
- 60-11 Pin 3x24
- 60-12 Pin of the buttplate
- 60-13 Pin of the stop of the stock
- 60-14 Pin of the pivot of the butt joint
- 60-15 Stock Bren 805 – (purchase)

SET OF THE TRIGGER MECHANISM OF THE WEAPON – BREAKDOWN OF THE COMPONENTS



- 40-01 Grip panel
- 40-02 Slide stop catch
- 40-03 Side plate – left
- 40-04 Side plate – right
- 40-05 Trigger
- 40-06 Pivot
- 40-07 Disconnector
- 40-08 Blocking of the trigger
- 40-09 Sear
- 40-10 Distance washer

- 40-11 Magazine catch
- 40-12 Button of the magazine catch
- 40-13 Safety catch
- 40-14 Blocking of the striker
- 40-15 Spring rod
- 40-16 Blocking of the stop of the magazine
- 40-17 Stop of the magazine Glock
- 40-18 Spring of the magazine catch
- 40-19 Spring of the disconnector
- 40-20 Spring of the sear

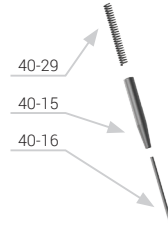

- 40-21 Spring of the blocking of the trigger
- 40-22 Spring of the stop of the magazine
- 40-23 Spring of the safety catch
- 40-24 Pivot of the blocking of the striker
- 40-25 Pivot of the blocking of the striker
- 40-26 Pin 3x22
- 40-27 Pin 4x20
- 40-28 Pin 4x22
- 40-29 Spring of the stop of the magazine

PACKAGE CONTAINS

Paper box with lining with indication of version and number of weapon

- Weapon in basic version with mechanical sights
- Glock Gen 4 magazine – 17 shots
- Shooting target
- Leaflet with information on safety instructions for using the weapon, with information on downloading the manual in pdf and a warranty card

WARRANTY GUIDELINES

- Warranty period for the weapon is 2 years
- Be mindful of the proper weapon handling according to these operating instructions. In the case of improper weapon handling, the manufacturer is not liable for the caused damages and the buyer loses its warranty
- Always use 9mm Luger / 9x21 ammunition conforming to C.I.P. standard – when using other ammunition, the manufacturer is not liable for the caused damages and the buyer loses its warranty
- Do not make any weapon modifications (especially not in the area of functional mechanisms) – in case of making any weapon modifications, the manufacturer is not liable for the caused damages and the buyer loses its warranty



WARRANTY CARD

Model and version
of the weapon:

Serial number:

Day – month – year of purchase
of the weapon by the buyer:

Name, registered office, company number
of the seller (stamp, signature):



Warranty record

1st repair

2nd repair

3rd repair



EXCLUSIVE SELLER

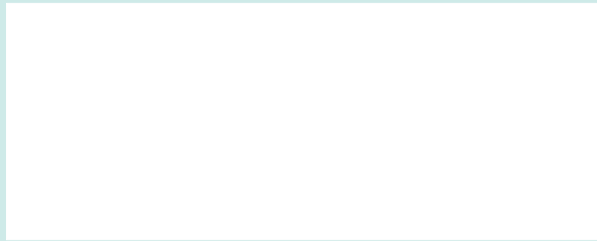

DISTRIBUTOR

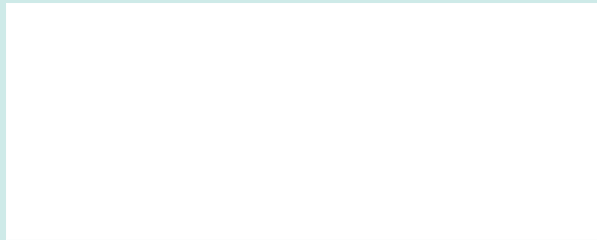

PRODUCED BY:

KR-WEAPONS s.r.o., Družstevní I/195, Hrádek na Vlárské dráze, 763 21 Slavičín, Czech Republic – Europe

E-mail: info@kr-weapons.com

www.kr-weapons.com